

LFS-03

Miniature pressure & vacuum switch

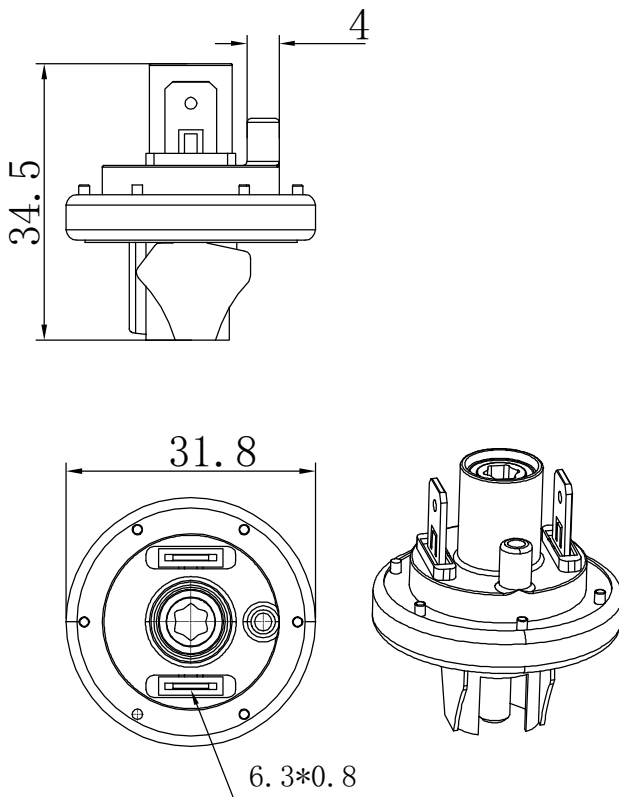

Dimension in:mm



LFS-03 can be applied to detection positive or negative pressure. It can be used as a gauge or differential pressure switch with almost no hysteresis. If 2 switch points are required, 2 pressure switches with different calibrations should be employed. The method of fixing the tab terminals to the switch body does not allow for absolute air sealing. The switch is therefore not recommended for applications where static vacuum has to be maintained. However, special models with additional pressure spring which allow for the vacuum to be connected to the pressure inlet side are available on request.

LFS-03 Order Ref NO

LFS-03 0 0 0 W10 R135 - V90

A B C D E F

A Connection Type:D=Pressure & Vacuum Connection ; 0=Vacuum Connection

B Contact Carrying parts(Dimension in mm):0=Brass Silver Plated ; G=Brass Golden Plated

C Connection Size:0=4mm OD tube (G1/8,NPT1/8,M10×1 Male connection are optional)

D Wire Lead:0=Without,Wxx=Length of wire lead in inches,i.e.W10=10inch wire lead;Terminal is available on customer's request

E Inlet Rotation:0=Aligned,Rxx=Angle(xx in Degrees) i.e.R135=135°

F Pressure setting in mbar :i.e. V90=90mbar vacuum, P90=90mbar positive

Specification

Model	LFS-03
Media	Non-hazardous gas only
Electrical Function	1 pole NO or 1 pole NC
Electrical Rating	250mA ,250V(Pmax:2.5bar)
Ambient Temperature	-10℃ to +90℃
Terminal	4.8mm×0.8mm copper alloy
Pressure Range	-15-800mbar
Maximum Pressure	2500mbar
Connection	Inlet 4.0mm for tube connection (Threaded inlet M10×1, NPT1/8 or G1/8 Male)

Conversion:1mbar=100Pa 1"W.C=249Pa

www.lefoo.com